

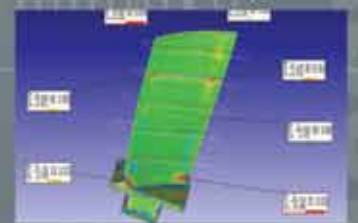

Non-contact multi-sensor 3D metrology system

# HN-6060

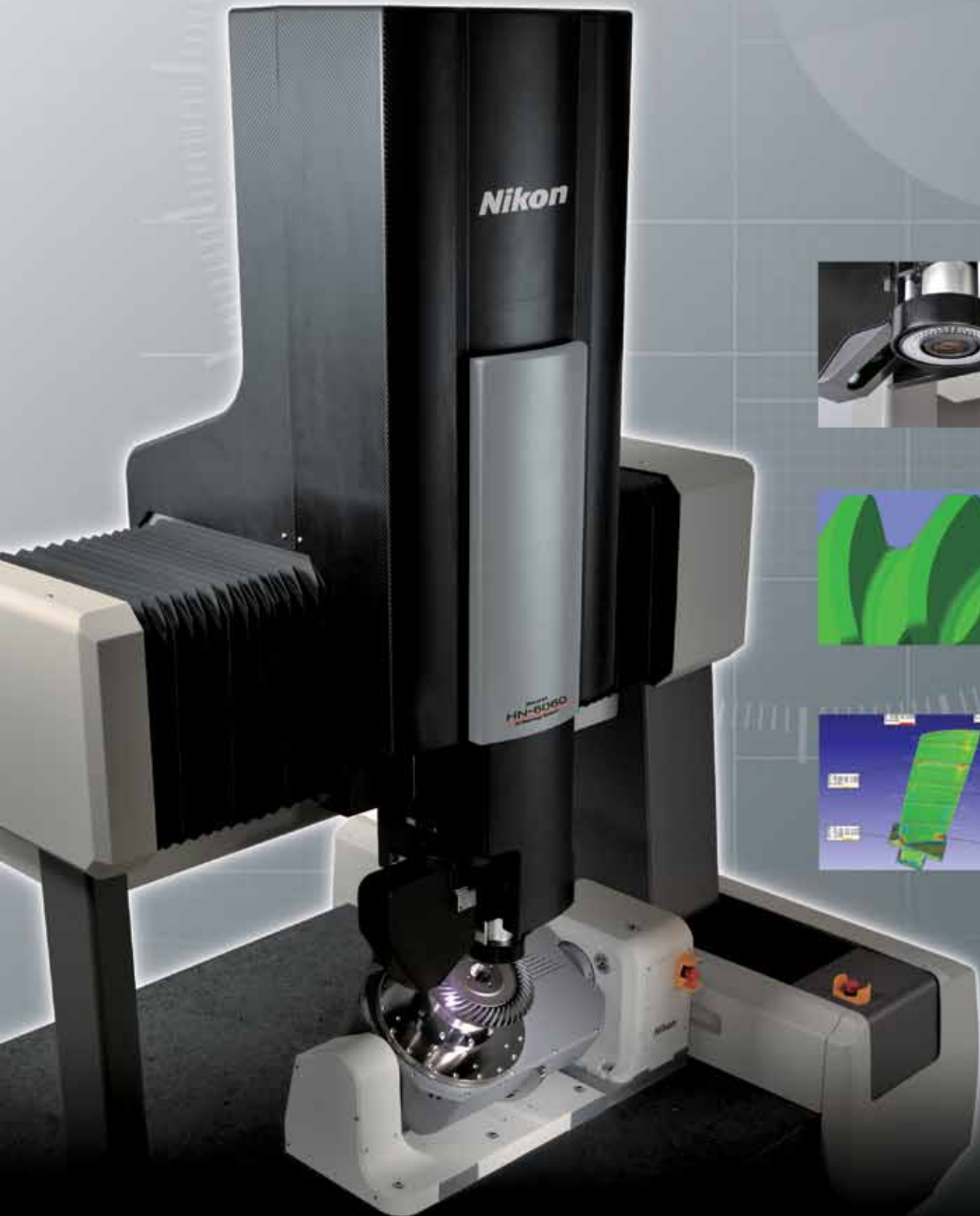

Metrology Production

# Nikon 3D metrology system — from critical dimension measurement to high- precision, non-contact shape inspection

The HN-6060 — Nikon's next-generation, non-contact, 3D metrology system is equipped with the latest multi-sensing metrology technologies, including a newly developed high-precision laser scanner that combines optical and image processing technologies. As a new generation metrology system, the HN-6060 assists the manufacturing process and assures product quality.



## Non-Contact Multi-Sensor 3D Metrology HN-6060

The HN-6060 non-contact, multi-sensor, 3D metrology system makes automatic shape measurement of complex components a reality. With a two-axis rotary table and a three-axis high-rigidity air bearing construction CMM, incorporating five-axis synchronous linear motor drive and control mechanism, the hardware has been optimized for stability. Additionally, with the adoption of Nikon's proprietary low thermal expansion encoder scales and a design optimized for minimizing Abbé errors, the accuracy of the this high-precision 3D measurement instrument is  $1.5+4L/1000 \mu\text{m}$ .

The HN-6060 is equipped with newly developed high-speed and high-precision laser scanner and SFF (shape from focus) sensor, which uses active texture projection to perform high-precision measurement of shapes even with glossy surfaces or with no surface texture. Touch probes and optical heads with built-in TTL laser AF (with proven performance in Nikon's NEXIV VMR series CNC Video Measuring System) complete the multi-sensor system. The system's use of multi-sensors allows it to perform diverse shape measurements of parts such as complex automotive and machined components, molded parts, medical devices etc.



# Metrology Drives



## The main features of the HN-6060

### High-precision and optimized shape capturing and measurement for 3D components

Nikon has combined leading-edge optical and hardware control technology and developed a laser scanner system that acquires point clouds with high precision at a rate of 120,000 points per second. The HN-6060 has proven its ability in comparison checking of surface shape inspection data with 3D CAD models (part-to-CAD comparison) and in reverse engineering.

### Enhanced multi-sensor technology enables shape inspection without manual preparation of samples

Using newly developed high-precision laser scanner, SFF and tactile sensors, and five axis hardware control, the system can perform many types of high-precision inspection of components and match processing for automatic assembly of point clouds. The system also allows high-precision, non-contact 3D inspection without manual preparation (such as application of powder to the object under inspection) of black molded components and shapes with glossy surfaces, which have traditionally been difficult to measure.

### Five-axis synchronized hardware control for high-precision metrology

In addition to a newly developed high-precision three-axis orthogonal drive system driven by linear motors, the system is also equipped with a two-axis rotary table. This technology allows for acquisition and inspection of point clouds at the optimum orientation necessary for gear inspection.



Gear Metrology: Automotive hypoid/spiral bevel gear teeth surface

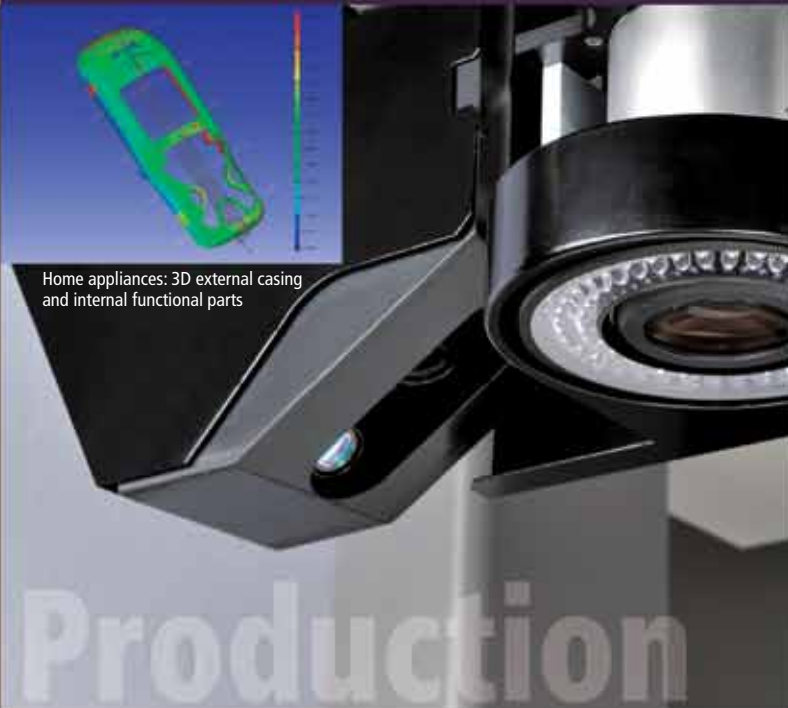

Home appliances: 3D external casing and internal functional parts

A high level of user operability is incorporated, including fixed viewpoint five-axis operation control (for easy acquisition of surface point clouds) plus simulation running mode.

With a design that takes full account of user safety and operability (such as fixed viewpoint joystick operation for easy acquisition of point clouds from 3D shapes and simulation for collision avoidance), the system makes non-contact shape inspection a reality.

### HN Metrology 3D — feature-rich 3D metrology software

The new HN Metrology 3D software represents an evolution in multi-sensor metrology software based on the dimension inspection software for the proven Nikon NEXIV VMR series. The user can easily make use of a wide variety of advanced functions for set-up, teaching, shape measurement, comparative error estimation with reference to 3D CAD data, and result output.

### Focus point cloud analysis software (optional)

The Focus Inspection option allows error comparison with reference to 3D CAD data and creation of detailed reports based on high-precision point cloud and mesh data. Point clouds can also be used for reverse engineering.

The HN-6060 metrology system assists, drives and streamlines the production process with high accuracy 3D digitizing and measuring capabilities. The unique system is designed in close cooperation with leading industrial manufacturers and offers many benefits to produce better products in a faster way.

Full 3D point cloud data of complex parts

Non-contact measurement

Manual preparation-free laser scanning

High precision and high quality

Fast, automated inspection

Easy operation

High rigidity 5 axis hardware

Multi-sensors cover a wide application range

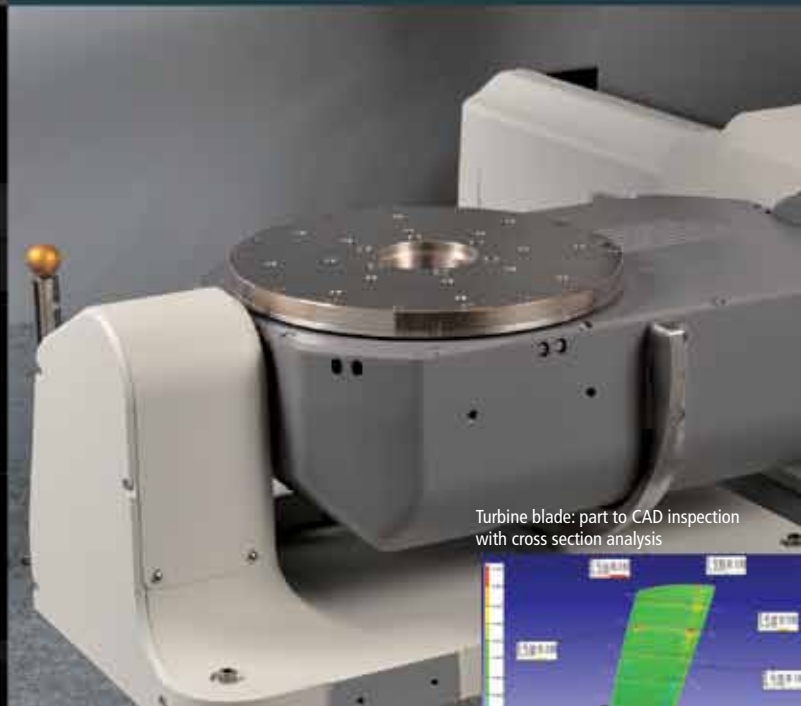

Turbine blade: part to CAD inspection with cross section analysis

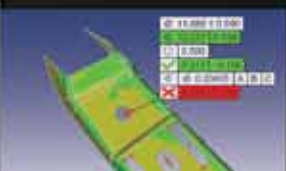

Pressed Parts: 3D surface form part to CAD inspection with GD&T evaluations

# The five-axis hardware control, which incorporates Nikon control technology, supports multi-sensor high-precision non-contact 3D metrology.

## CMM design for top accuracy

A linear motor drive mechanism is the heart of the three-axis orthogonal section, guaranteeing stable and high-precision inspection over a long period of time. Concurrently, the system also achieves high-precision positioning control. With the system's high-rigidity air bearing construction, the design has been optimized to compensate deformation caused by changes in temperature. Additionally, with the adoption of Nikon's proprietary low-temperature expansion encoder scales and a layout optimized to minimize Abbé errors, the accuracy of the high-precision 3D measurement hardware is  $1.5+4L/1000 \mu\text{m}$ .



The low thermal expansion linear encoder scales, which are key components in high-precision measurement, are manufactured in-house, using Nikon optical technology.

## High-precision, two-axis rotary stage

The adoption of a high-rigidity design enables control with high-precision positioning repeatability and unlimited angular rotation with a free swivel angle of up to 95°. Ideal for gear inspection, the system carries out inspection with the optimum sensor orientation for the stereoscopic shape of the target object.



## Ergonomic operator console

The console, which enables easy five-axis synchronized operation, features a simple configuration and includes switches for changing between sensors, and buttons for carrying out simple inspection. The fixed-viewpoint control function allows for easy control of the optimum sensor attitude for a particular shape.



## Calibration system for multi-sensor metrology

The system comes with a calibration set that is designed to enable non-contact, 3D metrology at the highest accuracy. This enables measurement with a single datum using a variety of different sensors. A specially made ball bar, traceable to the National Institute of Advanced Industrial Science and Technology's non-contact measurement standards is used for calibration of the main unit. This guarantees traceability to public and international agencies that require certified non-contact measurements of the highest precision.



Light sectioning sensor calibration



Touch-probe calibration

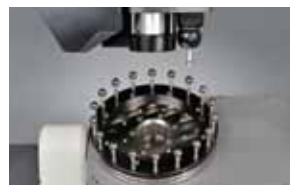

Five-axis precision calibration using a multi-datum ball



Non-contact measurement precision verification using a ball bar

# Multi-sensor measurement head featuring Nikon's newly developed high-precision laser scanner that attains non-contact measurement uncertainty of $5\ \mu\text{m}$ ( $E_s$ , $MPE$ ).

## Newly developed high-precision laser scanner

As a long-established manufacturer of high-quality optical instruments, Nikon took a completely fresh look at non-contact-sensor optical systems. In order to achieve measurement with such an unprecedentedly high degree of precision, Nikon developed special optics such as a newly designed cylindrical lens for the light emitter and an image-side telecentric optical system directing the object image to a detector with high precision. Nikon, also, designed the hardware mechanism suppressing variation in magnification due to changes in temperature. In addition, the implementation of a hinged optical system (in accordance with the Scheimpflug principle) enables surface data to be acquired with a constant focus above the detection device. A CCD with dramatically improved smear resistance has been employed for the light detecting section. In tandem with the bright optical system, this enables detection on low-reflectivity, or glossy surfaces without manual preparation such as spraying. The system has a built-in finder-camera for monitoring the surface measurement of an object. This enables the user to carry out measurement programming in the video window of the host PC and to monitor inspection in real time.

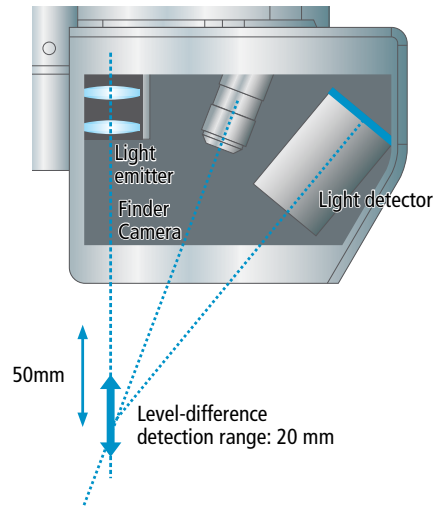

## High-speed high-density acquisition of shape point cloud data

High-speed digital transform processing enables surface point clouds to be acquired at the rate of 120,000 points per second. Fine Mode enables high-density acquisition of in-line point clouds with a line pitch of  $20\ \mu\text{m}$  — not only for shapes with features but also for surface waviness.

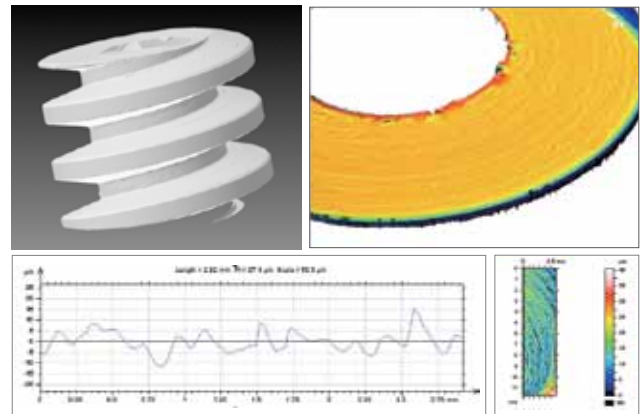

## Image-processing optical system with built-in SFF sensor and TTL laser AF, and 15x zoom

The system features the proven high-NA zoom optical system from the NEXIV VMR series CNC Video Measuring Systems — now illuminated exclusively with LEDs — as well as image processing developed in-house by Nikon. In addition, the system is equipped with the very latest SFF (shape from focus) inspection sensor. Using active texture pattern projection mechanism, the system can perform high-precision shape acquisition for surfaces that are as devoid of texture as the surface of a mirror, while TTL laser AF enables level difference and profile measurement.



Edge detection by image processing

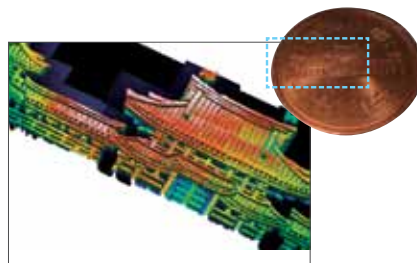

High-resolution small 3D surface metrology by SFF sensor

## Ready to fit with Renishaw touch probes

In cases where touch probes are required for datum shape acquisition (for example, with cylindrical shapes), measurement with the TP200 trigger sensors, as fitted to the PH1, is effective.



# HN Metrology 3D software makes straightforward high-precision non-contact 3D metrology a reality

## Multi-sensor 3D metrology software

Newly developed HN Metrology 3D metrology software integrates a whole range of tasks, including touch probe and image-processing measurement, acquisition of point clouds using light section and SFF sensors, and part to 3D CAD model for deviation comparison. The software measures the dimensions and shape of the object under inspection in diverse ways.

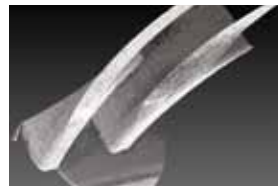
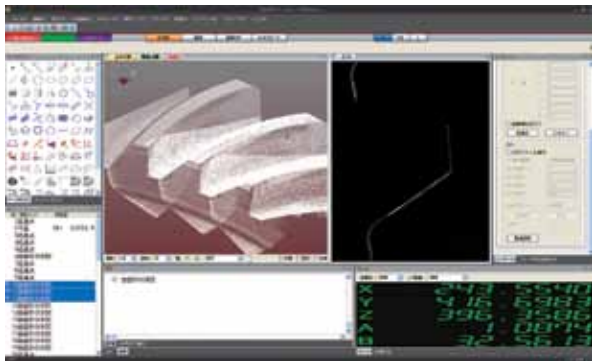

Point cloud data of part surfaces



Nominal Shape data  
(3D CAD Model)

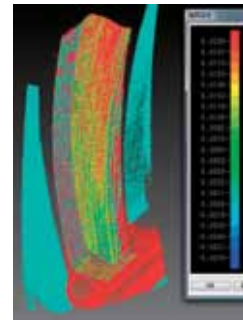

Part to CAD Deviation Display  
with color mapping

## On-line/off-line operation function simulator

When sampling complex shapes, it is possible to read the model data and to verify device operation prior to actual measurements using either the On-Line or Off-Line Simulator Mode.



## Ready for reverse engineering (option)

As the resulting scan data is a 3D point cloud, the data can also be used for various reverse engineering purposes. This technology is typically used to create CAD from handmade clay models, to regenerate CAD data from existing parts when the original CAD data is missing, to update designs from part surface data produced by high yield dies & molds, or to serve as input for rapid prototyping of freeform parts and products.

## Focus Inspection point cloud software (option)

Focus Inspection is the standard point cloud inspection software application. This software boasts outstanding metrology functions, an intuitive user interface, and standard macro functionality, enabling the entire inspection process to be automated. Focus Inspection enables partial or total 3D part-to-CAD inspection based on mesh data or point cloud data from a CMM scanner or handheld scanner, or from CT (Computed Tomography) data. Focus Inspection can be used to create easy-to-interpret interactive inspection result tables and reports.

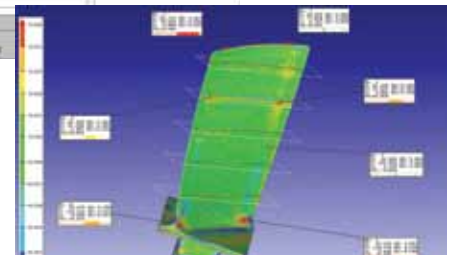
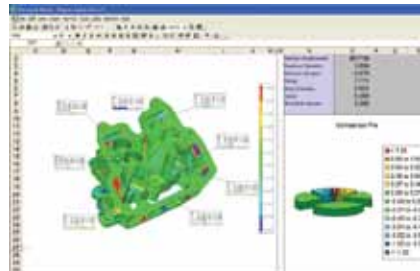

Knee implant -  
point cloud data

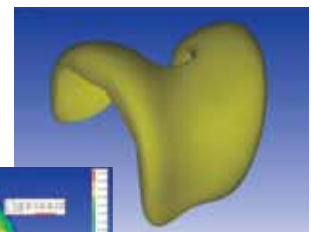

CAD Model

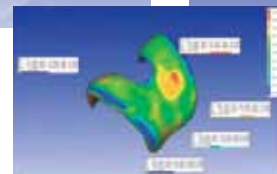

Part to CAD comparison

## Specifications

HN-6060 Main unit and rotary table		
Orthogonal three-axis stroke (X×Y×Z)	600 mm × 600 mm × 600 mm (24" × 24" × 24")	
Orthogonal three axis hardware accuracy	Maximum Permissible Error $E_{MPE}$ : 1.5+4L/1000um - ISO10360-2, JIS7440-2: 2003	
Two-axis rotary table	Maximum diameter ( $\varphi$ ) of object under inspection	300 mm
	Maximum height (H) of object under inspection	200 mm
	Maximum weight of object under inspection	20 kg
Dimensions of main unit	1850 mm (W) x 1540 mm (D) x 2650 mm (H)	
Weight of main unit	2600 kg	
Recommended dimensions of space for installation	3500 mm (W) × 3500 mm (D) × 2800 mm (H) (including mounting surface for controller and for operation devices for host computer)	
Guidance system	Air bearings	
Maximum drive speed	300 mm/sec. in each axis (X, Y, and Z)	
Multi-sensor head		
High-precision laser scanner	Operating distance	50 mm (from the center of the measurement range)
	Measurement distance	20 mm linear
	Height detection range	±10 mm
	Total accuracy	5 $\mu$ m ( $E_s$ , $MPE$ ) – Maximum Permissible Error of sphere-spacing measurement – JIS B 7441: 2009
	Linear resolution	20 $\mu$ m
	Laser class	Class 2
Image probe	Camera	1/3-inch 3-CCD progressive scan camera
	Operating distance	50 mm
	Magnification range	Optical magnification: 1x – 15x Screen magnification: 36x – 540x
	FOV size	From 4.67 mm × 3.5 mm to 0.311 mm × 0.23 mm
	Illumination device	Epi-illumination: white LEDs Ring illumination: illumination by 8 distributed white LEDs Transmitted-light illumination: supplied on special order basis
	TTL laser AF	Height detection in single point focus and scan mode, Laser class 1M
	SFF (shape from focus)	5 $\mu$ m ( $P_{FF}$ , $MPE$ ) - Maximum Permissible Error of flat form measurement (at 4x) - JIS B 7441: 2009
	Touch probes	Probe heads
Touch probes		Renishaw TP20 or TP200
Accuracy		1.5 $\mu$ m ( $MPE_p$ ) - Maximum Permissible Error for probing (with TP200) - JIS B 7440-2: 2003, ISO 10360-2:2003
Stylus changer		MCR20 Module Change Rack
Installation requirements	Power	200 V ± 10%, 20 A
	Barometric pressure	0.6 Mpa
	Temperature for guaranteed accuracy	20°C ± 0,5K
	Permissible floor vibration	–10 Hz, ≤ 3 $\mu$ m P-P, 10 Hz– with speed of acceleration ≤ 0.012/s <sup>2</sup> m
Host computer	OS	Windows 7, 64-bit editions
	Interface	USB 2.0 x 1, IEEE1394b x 1

## Dimensions

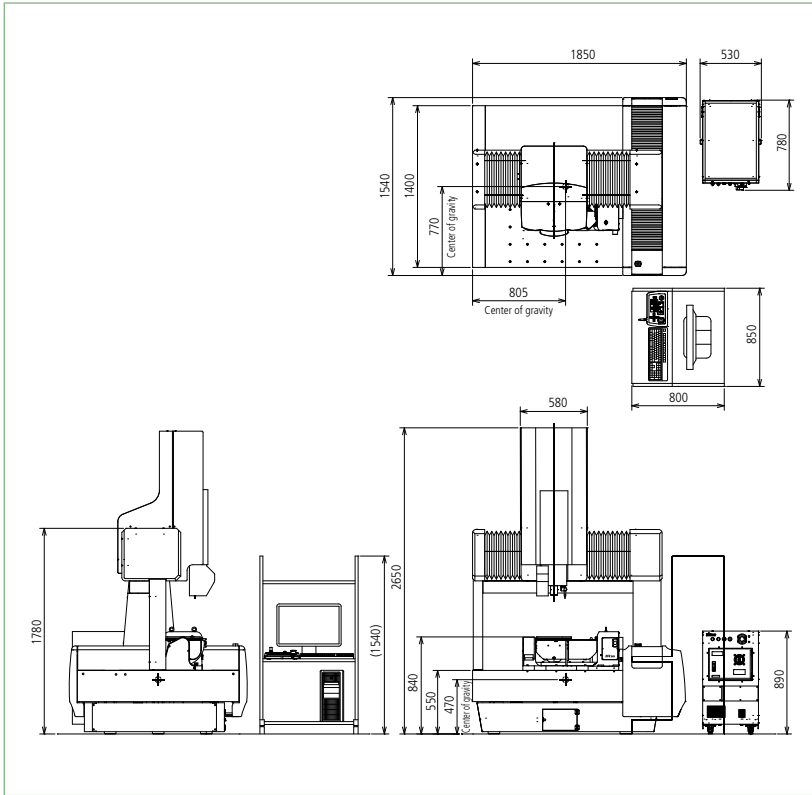

## Top surface

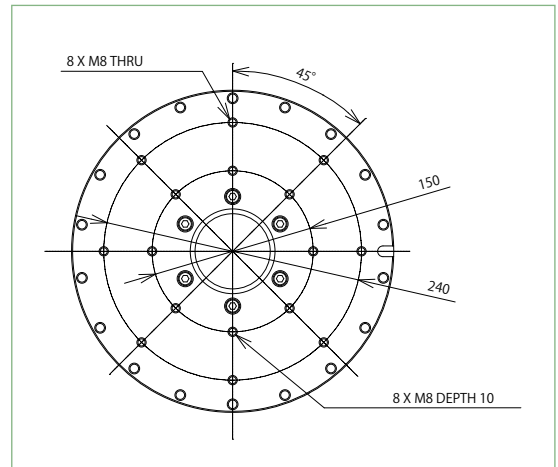
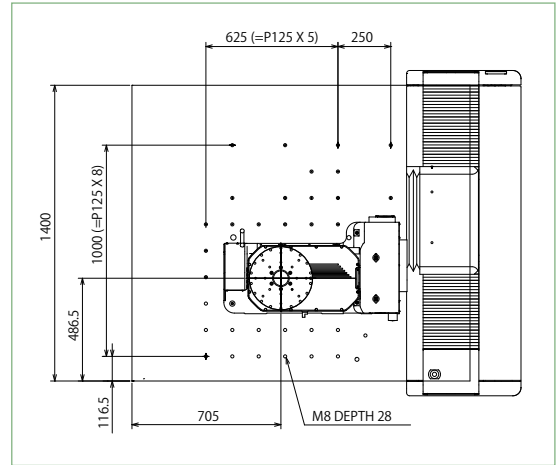

**WARNING** TO ENSURE CORRECT USAGE, READ THE CORRESPONDING MANUALS CAREFULLY BEFORE USING YOUR EQUIPMENT.

Specifications and equipment are subject to change without any notice or obligation on the part of the manufacturer. October 2010 ©2005-10 NIKON CORPORATION

N.B. Export of the products\* in this catalog is controlled under the Japanese Foreign Exchange and Foreign Trade Law. Appropriate export procedure shall be required in case of export from Japan.

\* Products: Hardware and its technical information (including software)

- Monitor images are simulated.
- Company names and product names appearing in this brochure are their registered trademarks or trademarks.



### NIKON CORPORATION

Shin-Yurakucho Bldg., 12-1, Yurakucho 1-chome, Chiyoda-ku, Tokyo 100-8331, Japan  
phone: +81-3-3216-2384 fax: +81-3-3216-2388  
<http://www.nikon.com/instruments/>



ISO 9001 Certified  
for NIKON CORPORATION  
Instruments Company



ISO 14001 Certified  
for NIKON CORPORATION

### NIKON METROLOGY, INC.

12701 Grand River Avenue, Brighton, MI 48116 U.S.A.  
phone: +1-810-220-4360 fax: +1-810-220-4300  
E-mail: [sales\\_us@nikonmetrology.com](mailto:sales_us@nikonmetrology.com)  
<http://us.nikonmetrology.com/>  
<http://www.nikoninstruments.com/>

### NIKON METROLOGY EUROPE NV

Geldenaaksebaan 329, 3001 Leuven, Belgium  
phone: +32-16-74-01-00 fax: +32-16-74-01-03  
E-mail: [sales\\_europe@nikonmetrology.com](mailto:sales_europe@nikonmetrology.com)  
<http://www.nikonmetrology.com/>

### NIKON INSTRUMENTS (SHANGHAI) CO., LTD.

CHINA phone: +86-21-6841-2050 fax: +86-21-6841-2060  
(Beijing branch) phone: +86-10-5831-2028 fax: +86-10-5831-2026  
(Guangzhou branch) phone: +86-20-3882-0552 fax: +86-20-3882-0580

### NIKON SINGAPORE PTE LTD

SINGAPORE phone: +65-6559-3618 fax: +65-6559-3668

### NIKON MALAYSIA SDN BHD

MALAYSIA phone: +60-3-7809-3688 fax: +60-3-7809-3633

### NIKON INSTRUMENTS KOREA CO., LTD.

KOREA phone: +82-2-2186-8400 fax: +82-2-555-4415

### NIKON INDIA PRIVATE LIMITED

INDIA phone: +91-124-4688500 fax: +91-124-4688527

### NIKON CANADA INC.

CANADA phone: +1-905-602-9676 fax: +1-905-602-9953

### NIKON INSTRUMENTS S.p.A.

ITALY phone: +39-055-300-96-01 fax: +39-055-30-09-93

### NIKON AG

SWITZERLAND phone: +41-43-277-28-67 fax: +41-43-277-28-61

### NIKON GMBH AUSTRIA

AUSTRIA phone: +43-1-972-6111-00 fax: +43-1-972-6111-40

### NIKON BELUX

BELGIUM phone: +32-2-705-56-65 fax: +32-2-726-66-45

### NIKON METROLOGY UK LTD.

UNITED KINGDOM phone: +44-1332-811-349 fax: +44-1332-639-881

E-mail: [sales\\_uk@nikonmetrology.com](mailto:sales_uk@nikonmetrology.com)

### NIKON METROLOGY SARL

FRANCE phone: +33-1-60-86-09-76 fax: +33-1-60-86-57-35

E-mail: [sales\\_france@nikonmetrology.com](mailto:sales_france@nikonmetrology.com)

### NIKON METROLOGY GMBH

GERMANY phone: +49-6023-91733-0 fax: +49-6023-91733-19

E-mail: [sales\\_germany@nikonmetrology.com](mailto:sales_germany@nikonmetrology.com)